

TABLE OF CONTENTS

SECTION ☿ ESSENTIAL PARTS

Names of Parts 2

SECTION ☿ GETTING READY TO SEW

Connecting the Machine to the Power Supply ..	3
Foot Control	3
Sewing Light	3
Extension Table (Accessory storage Box).....	4
To Snap On and Snap Off the Presser Foot ...	4
Changing Needles	5
Thread and Needle Chart	5
Setting Spool Pin	6
Removing or Inserting the Bobbin Case	6
Winding the Bobbin	6
Threading Bobbin Case	7
Threading the Machine	7
Drawing Up Bobbin Thread	8
Balancing Needle Thread Tension	8
Stitch Selector	9
Stitch Length Control	9

Adjusting Stretch Stitch Balance	10
Reverse Stitch Control	10
Darning Plate	10
Left Needle Position	10

SECTION ☿ BASIC SEWING

Straight Stitch Sewing	11
To Change the Sewing Directions	11
Zigzag Stitching	11

SECTION ☿ UTILITY STITCHING

Overcasting	12
Overedge Stitch	12
Tricot Stitch	12
Triple Stretch Stitch	12
Zipper Application	13
Rolled Hem	13

Sewing Buttons	14
Buttonhole Stitching	15

SECTION ☿ DECORATIVE STITCHING

Shell Tuck	16
Stretch Stitch Patterns	16

SECTION ☿ CARE OF YOUR MACHINE

Dismantling and Assembling Hook Race	17
Cleaning the Feed Dogs	17
Oiling	17
Trouble Shooting	18

ESSENTIAL PARTS

Names of Parts

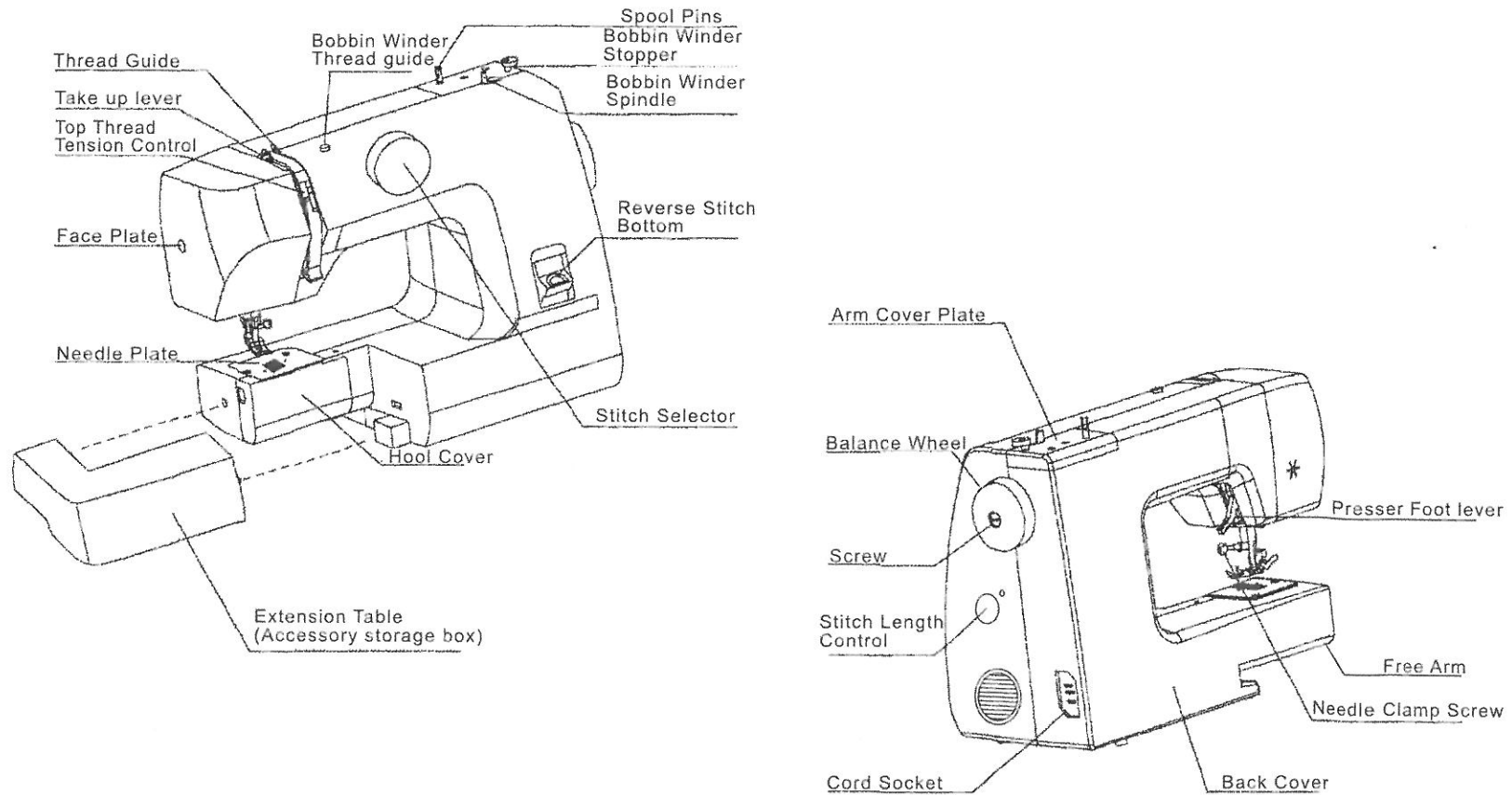

GETTING READY TO SEW

Connecting the Machine to the Power Supply

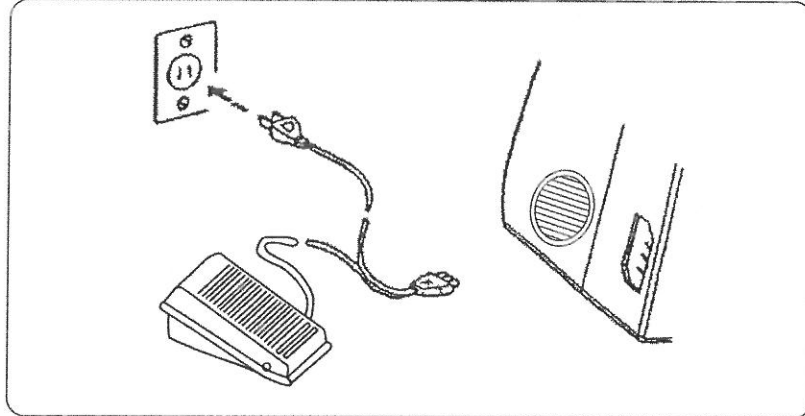

Before connecting the power, make sure the voltage and frequency of your electrical power conform to the machine.

Fit the nonreversible plug into the cord socket and plug the machine into the power supply.

Foot Control

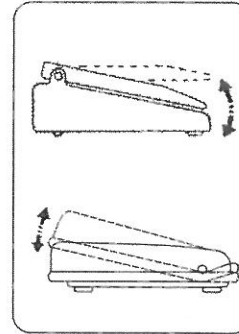

Sewing speed can be varied by the foot control.

The harder you press on the control, the faster the machine runs.

Sewing Light

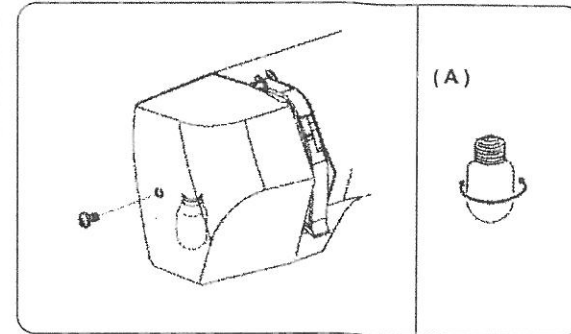

The sewing light is located behind the face plate.

Turn the screw counter-clockwise and remove the face plate.

(A) ● To remove Turn to the left.

● To replace Turn to the right.

Extension Table (Accessory Storage Box)

Extension Table

The extension table provides added sewing surface and can be easily removed for free arm sewing.

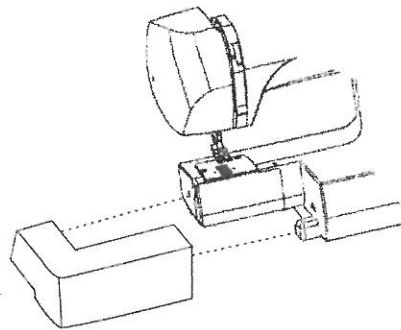

For free arm sewing

Pull the end of the extension table away from the machine, as illustrated.

For attaching the table

Push the extension table until its lugs fit into the machine.

To Snap On and Snap Off the Presser Foot

To snap off

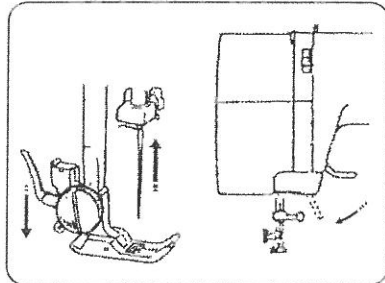

Turn the balance wheel toward you to raise the needle to its highest position. Raise the presser foot.

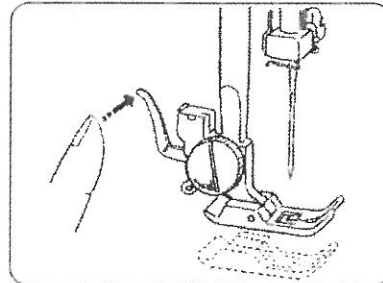

Press the lever on the back of the foot holder. The presser foot will drop off.

To snap on

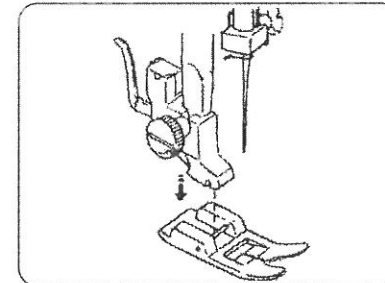

Place the presser foot so the pin on the foot lies just under the groove of the foot holder. Lower the foot holder to lock the foot in place.

Changing Needles

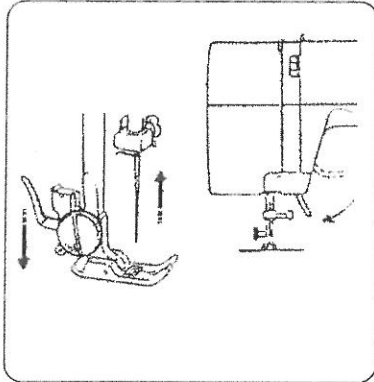

Raise the needle by turning the balance wheel toward you and lower the presser foot.

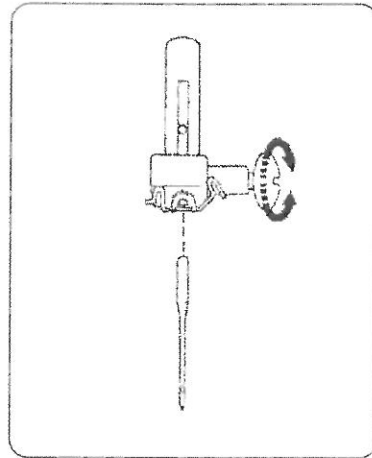

Undo the needle clamp screw just enough to release the needle.

Switch off the machine and disconnect the machine from the power point.

Loosen the needle clamp screw by turning it counter-clockwise.

Remove the needle from the clamp.

Insert the new needle into the needle clamp with the flat side away from you.

When inserting the needle into the clamp, push it up as far as it will go and tighten the clamp screw firmly with the screwdriver. Thread the needle.

Reconnect the machine to the power point, switch on the machine and continue to sew.

* Check your needles frequently for barbed or blunted points. Snags and runs in knits, fine silks and silk-like fabrics are permanent and are almost always caused by a damaged needle.

Thread and Needle Chart

- In general, fine threads and needles are used for sewing thin fabrics, and thicker threads and needles are used for sewing heavy fabrics. Always test thread and needle size on a small piece of fabric which will be used for actual sewing.
- Use the same thread for needle and bobbin.
- When sewing stretch, very fine fabrics and synthetics, use a BALL POINT needle. The blue tipped needle effectively prevents skipped stitches.
- When sewing very fine fabrics, sew over a piece of paper to prevent fabric distortion.

	Fabrics	Threads	Needle Size
Light weight	Crepe de Chine, Voile Lawn, Organdy, Georgette, Tricot	Fine Silk Fine Cotton Fine Synthetic Fine Cotton Covered Polyester	9 or 11
Medium weight	Linen, Cotton, Pique, Serge, Double Knits, Percale	50 silk 50 to 80 Cotton 50 to 60 Synthetic Cotton Covered Polyester	11 or 14
Heavy weight	Denim, Tweed, Gabardine, Coating, Drapery and Upholstery Fabrics	50 silk 40 to 50 Cotton 40 to 50 Synthetic Cotton Covered Polyester	14 or 16

Denim —

Jeans
Needle (16)

Setting Spool Pins

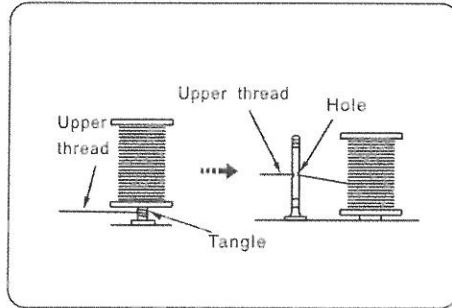

To use pull up the spool pin. Push down for storage.
If the thread would slip down from the spool, thread through the hole of spool pin as shown.

Removing or Inserting the Bobbin Case

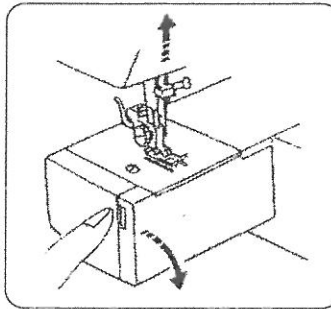

Open the hook cover.

Switch off the machine while doing this.

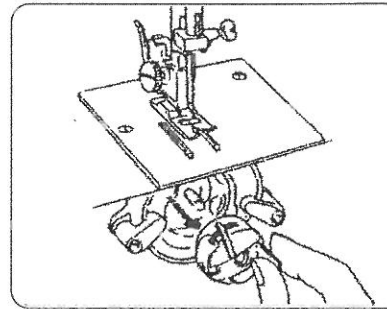

Raise the needle by turning the balance wheel toward you.
Take out the bobbin case by holding the latch.

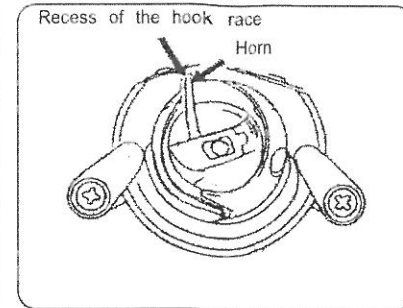

When inserting the bobbin case, place the horn into the recess of the hook race.
Switch on the machine.

Winding the Bobbin

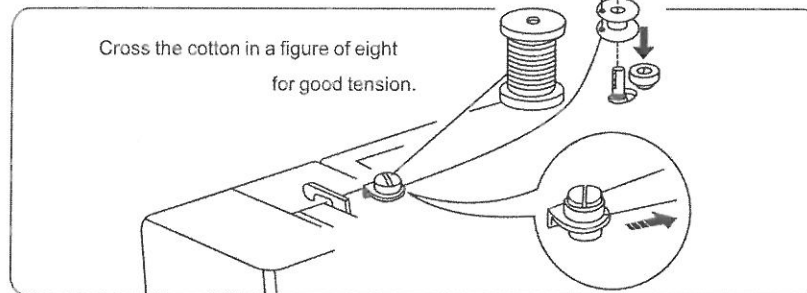

Draw thread from spool. Guide the thread around the bobbin winder thread guide.
Insert the thread through one of the holes in the bobbin from the inside to the outside.
Put the bobbin on the bobbin winder spindle, and push it to the right.

With the free end of the thread held in your hand, depress the foot control. Stop the machine when it has made a few turns, and cut the thread close to the hole in the bobbin. Depress the foot control again.

When the bobbin is fully wound, it will stop automatically.

Return the bobbin winder to its original position by moving the spindle to the left, and cut the thread.

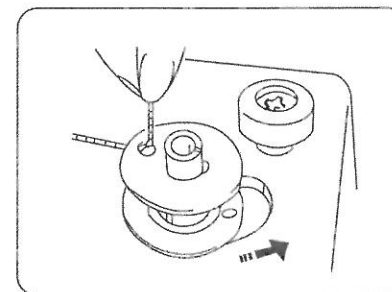

Threading Bobbin Case

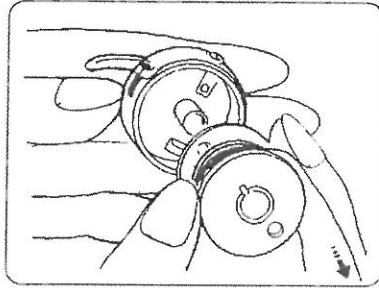

Place bobbin into bobbin case. Make sure the thread unwinds in the direction of arrow.

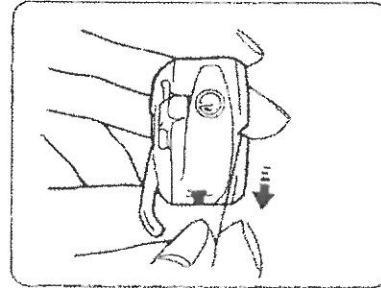

Pull the thread into the bobbin case slot.

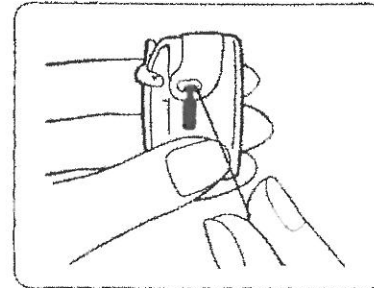

Draw the thread under the tension spring and into the delivery eye.
* Leave about 10 cm (4 inches) of free thread.

Threading the Machine

Always thread your machine with the power off

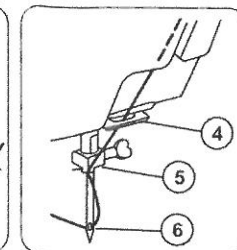
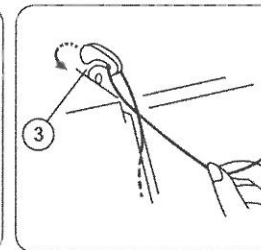
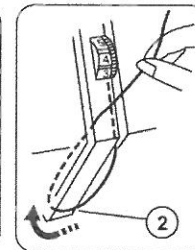
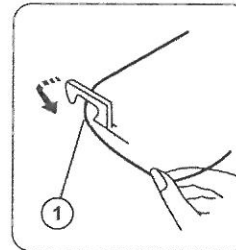
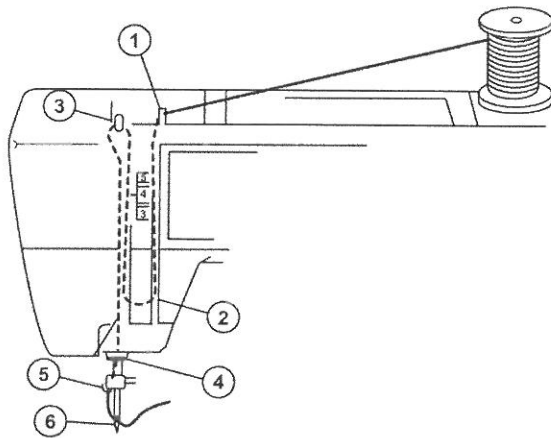

Raise take-up lever to its highest position by turning balance wheel toward you.

Raise presser foot.

Place spool on spool pin as shown, with thread coming from the back of the spool.

1. Draw thread into thread guide using both hands.
2. While holding thread near spool, draw thread down into the tension area and then around the check spring holder.
3. Firmly draw thread up and through take-up lever from right to left.
4. Then draw thread down and slip it into the lower thread guide.
5. Draw thread down and slip it into needle bar thread guide.
6. Thread needle eye from front to back.

NOTE: You may want to cut the end of thread with a pair of sharp scissors for easier needle threading.

Switch on the power after threading the machine and bobbin. You are now ready to sew.

Drawing up Bobbin Thread

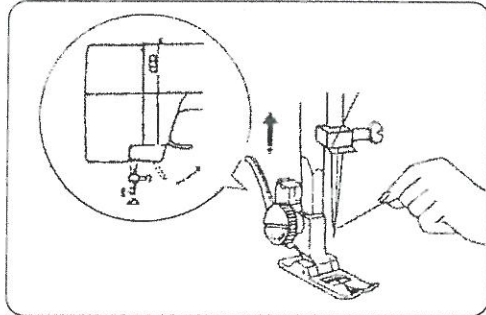

☐ Raise presser foot and hold the needle thread lightly with your left hand.

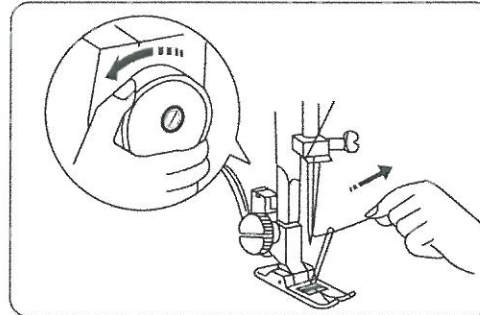

☐ Turn the balance wheel slowly towards you with your right hand until the needle goes down and continue turning balance wheel until the take-up lever is at its highest position. Lightly draw up the needle thread forming a loop of the bobbin thread.

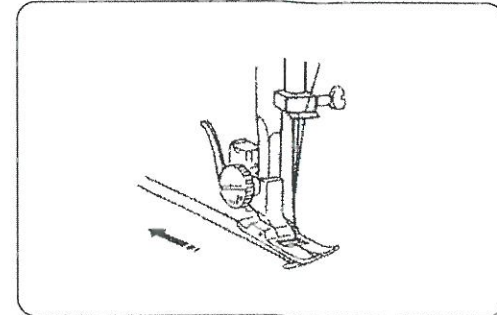

☐ Pull 15 cm (6") of both threads back and under the presser foot.

Balancing Needle Thread Tension

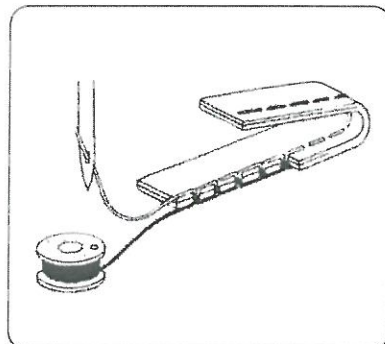

The needle thread and the bobbin thread should interlock in the center of two layers of fabric in straight stitch seams.

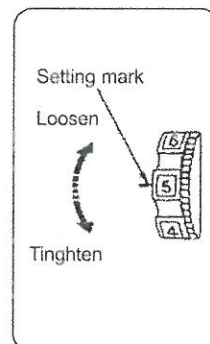

Set the desired number of the thread tension dial at setting mark.

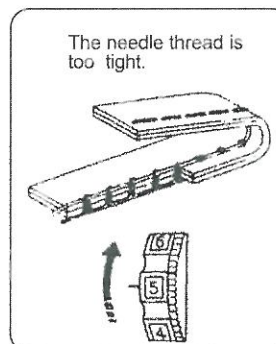

The needle thread is too tight.
Loosen the needle thread tension by moving the dial to a lower number.

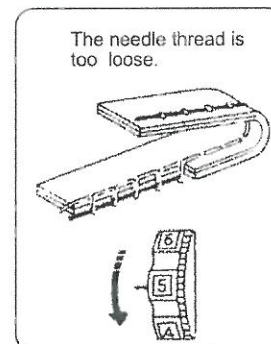

The needle thread is too loose.
Tighten the needle thread tension by moving the dial to a higher number.

Thread Tension for Zigzag Sewing

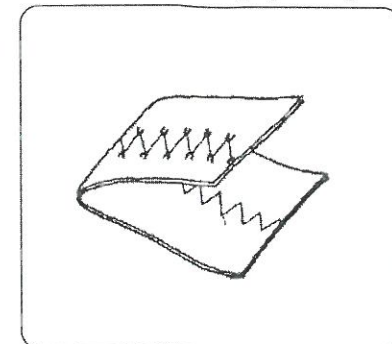

To obtain better zigzag stitches, the upper tension should be slightly lower than in the case of straight sewing. The upper thread should appear slightly on the reverse side of the fabric.

Stitch Selector

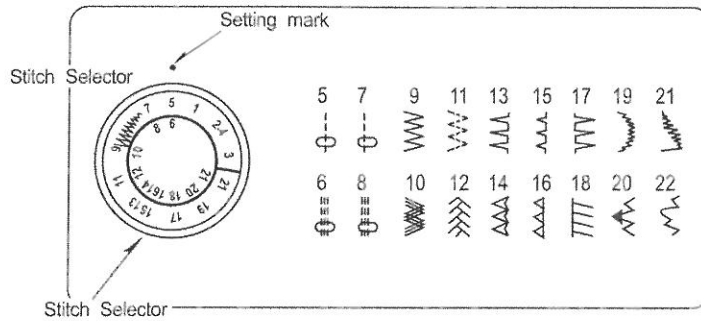

The stitch selector not only determines the stitch you select, but also regulates the stitch width for regular zigzag and rick rack stretch stitches.

NOTE: To avoid needle or fabric damage, be sure your needle is up and out of the fabric when adjusting this control.

Stitch Length Control

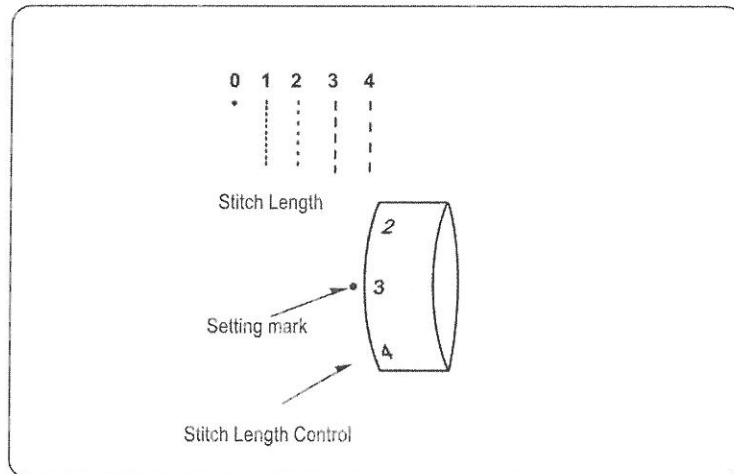

The stitch length control regulates the length of stitch, and also has a stretch stitches setting.

The higher the number, the longer the stitch.

"0" means no feed.

Depending upon your fabric or your own preference in buttonholes, you may alter the buttonhole stitch density within the buttonhole range () on the stitch length control.

Adjusting Stretch Stitch Balance

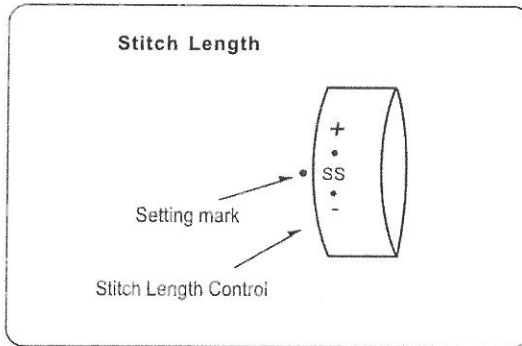

To select Stretch Stitches, set this control at SS position.

In stretch stitch sewing, Stretch Length Control should be in the Center position between-and+(SS position) for most materials. Depending upon the type of fabric used, you may need to adjust this control to match forward stitches of stretch sewing with reverse motion stitches.

To shorten stretch stitches, turn the control slightly toward "-". To lengthen, turn toward "+"

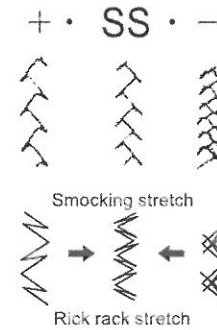

Reverse Stitch Control

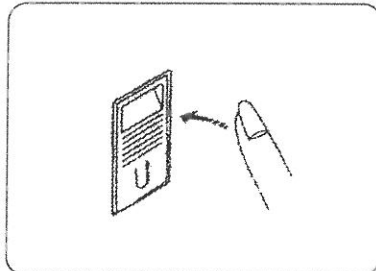

As long as you keep the reverse stitch control depressed, the machine sews backwards.

Darning Plate

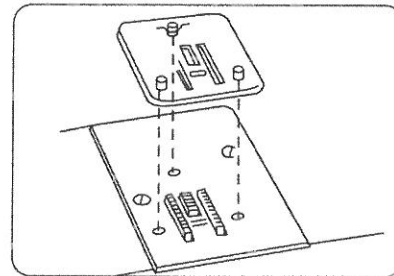

To Put on the Darning Plate:

1. Position the darning plate with the 3 pins on the bottom.
2. Fit the darning plate pins into the needle plate holes. The feed dogs will show through the darning plate holes.

Left Needle Position

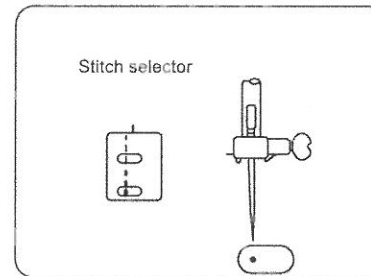

Use Left Needle Position for more control while topstitching or edge stitching difficult fabrics.

NOTE: Use only zigzag presser foot for Left Needle Sewing.

BASIC SEWING

Make sure the take-up lever is at the highest position before starting

Straight Stitch Sewing

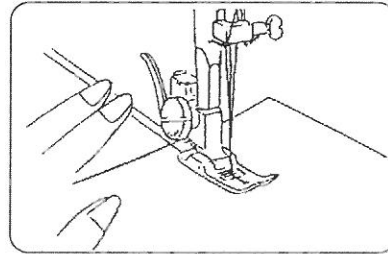
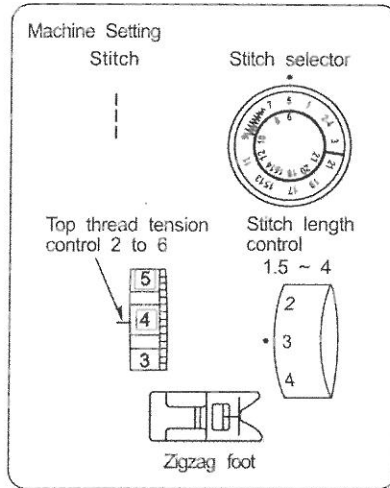

Raise the presser foot and position the fabric under the presser foot.

Lower the presser foot and smooth the threads toward the back. Depress the foot control.

Gently guide the fabric letting the fabric feed by itself.

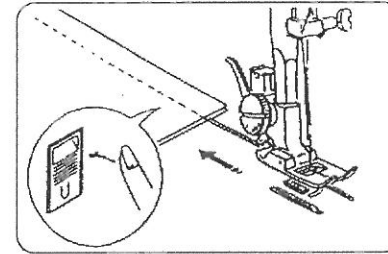

For fastening the ends of seams, press the reverse stitch control and sew several reverse stitches.

Raise the presser foot and remove the fabric, drawing the threads to the back.

If the fabric won't release turn the hand wheel towards you to complete the stitch, and gently pull out material

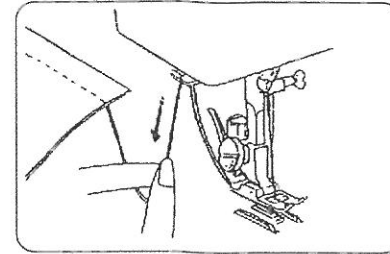

The threads are cut the proper length for starting the next seam.

To Change the Sewing Directions

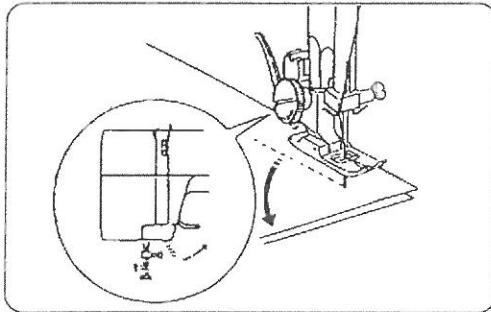

Stop the machine and turn the balance wheel toward you to bring the needle down into the fabric.

Raise the presser foot.

Pivot the fabric around the needle to change sewing direction as desired. Lower the presser foot and continue sewing.

Zigzag Stitching

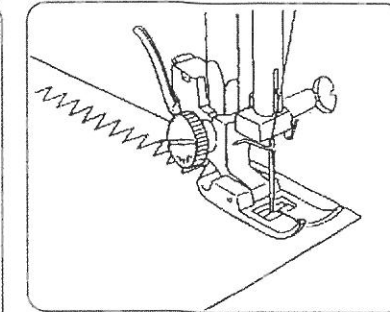
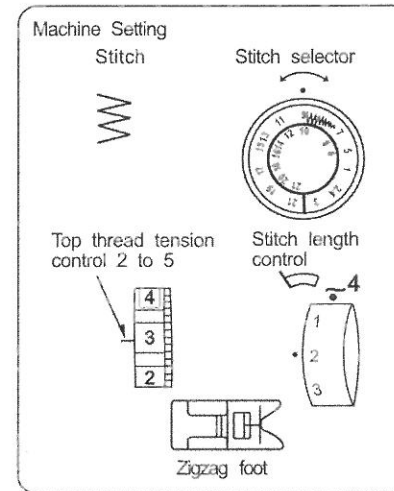

Simple zigzag stitching is widely used for overcasting, sewing on buttons etc.

UTILITY STITCHING

Overcasting

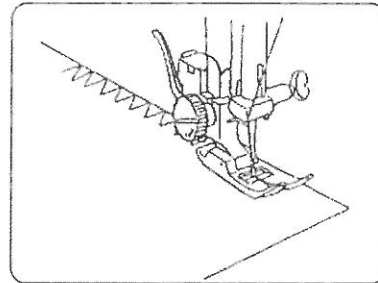
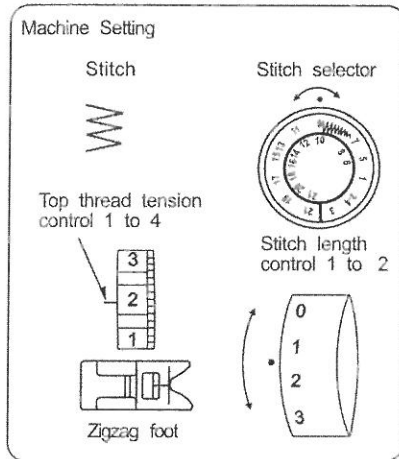

This type of stitch is used on the seam allowance to prevent fabrics from fraying at raw edges.

Overedge Stitch

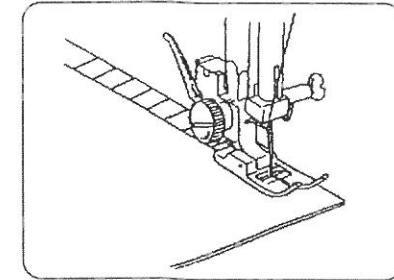
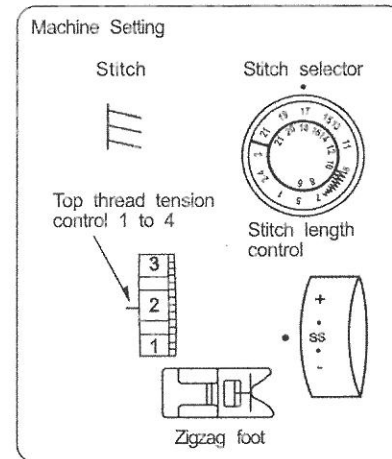

Overedge stitch will be done most successfully when the right side stitches of zigzag fall slightly off the edges of the fabrics.

Tricot Stitch

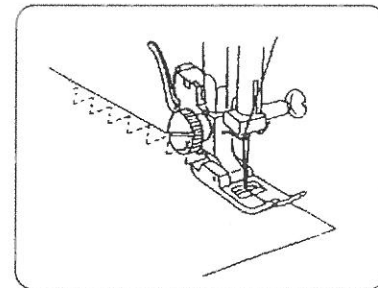
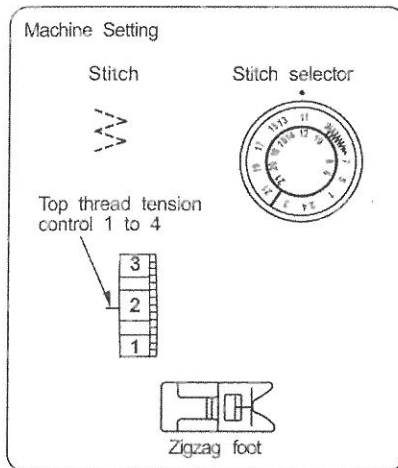

Place the fabric under the presser foot so that the edge will be slightly inside the right hand side of the presser foot. Guide the work so the right hand stitches fall at the edge of the fabric.

Triple Strength Stitch

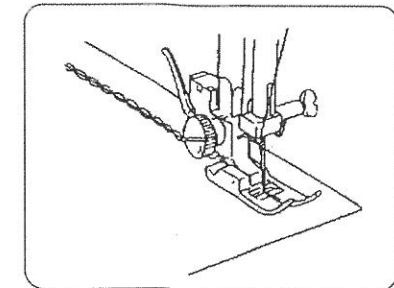
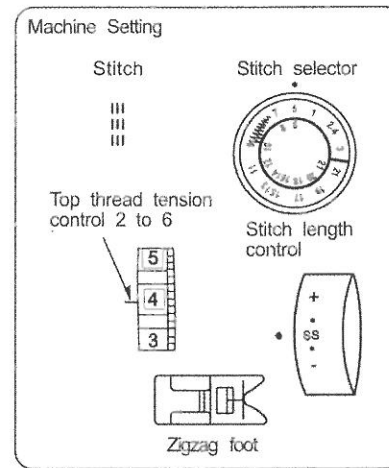

The stitch is sewn with two stitches forward and one stitch backward forming a seam that does not rip easily.

Garments should be basted for fitting before seaming.

Zipper Application

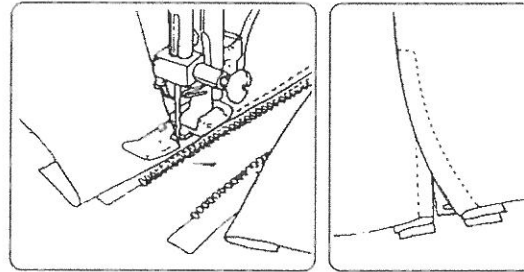
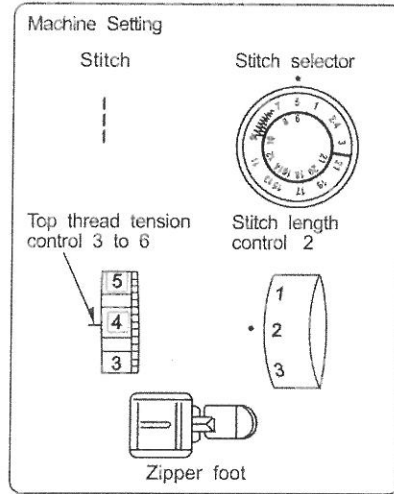

Pin or baste zipper tape to fabric and place it under the foot.
Smooth the threads toward the back and lower the foot. To sew left side of the zipper, guide the edge of the zipper along the zipper teeth and stitch through garment and zipper tape.
Turn the fabric and sew the other side of the zipper in the same way as you did on the left side of the zipper.

Rolled Hem

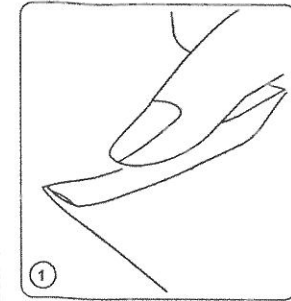
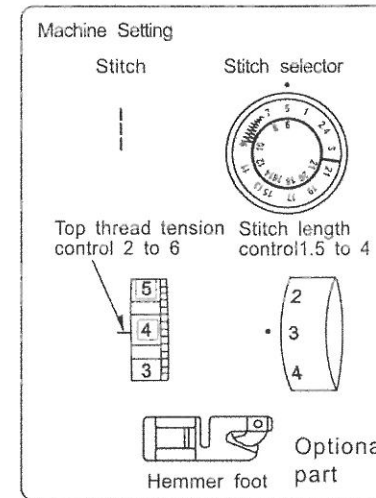

Make a double 0.25 cm (1/8") fold approximately 8 cm (3") in length.

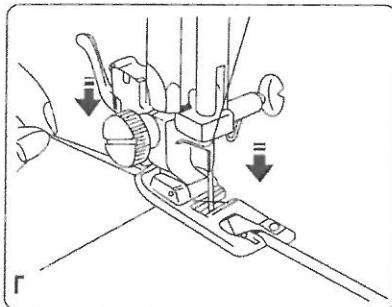

Lower the needle into the fabric at the point where sewing is to begin, then lower the hemmer foot.

Sew 3 or 4 stitches while holding the needle and bobbin threads

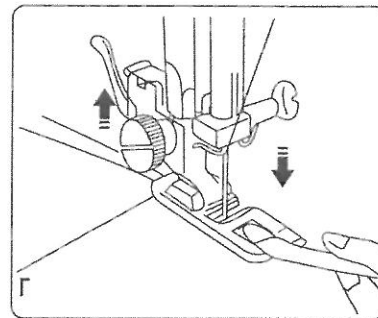

Insert the folded portion of the fabric into the curl of the hemmer foot.

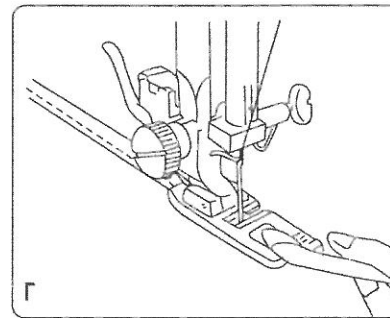

Lower the hemmer foot, then sew by lifting up the edge of the fabric to keep it feeding smoothly and evenly

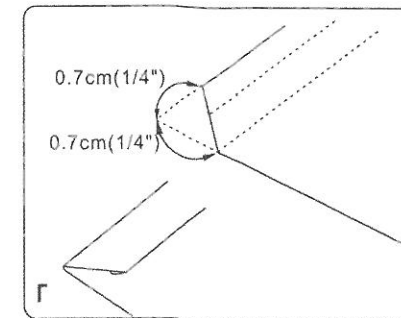

Trim about 0.7 cm (1/4") from corners as illustrated, to reduce bulk.

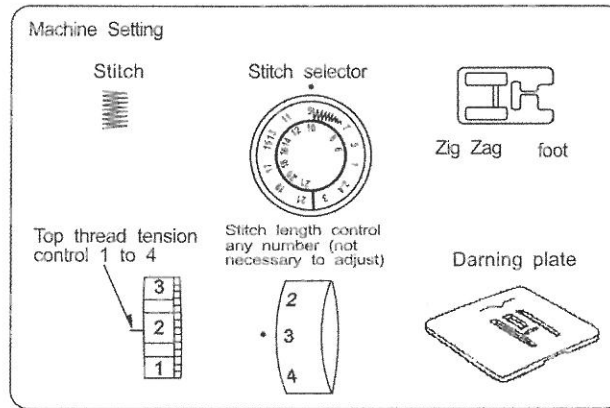

Sewing Buttons

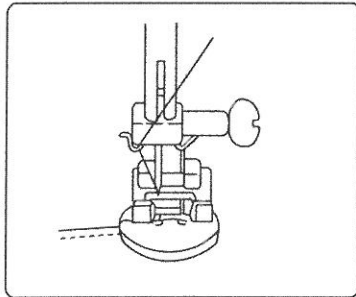

Use the darning plate for button sewing. (See page 10)



A pin can be placed on top of the button to form a shank.

Set the stitch selector at "  ". Align both holes of the button with the slot of the foot and place the left hole of the button just below the needle point. Lower the foot and turn the pattern selector until the needle point comes just above the right hole of the button. Sew about five stitches and raise needle. Set the stitch selector at "  " again and sew a few stitches to lock thread.

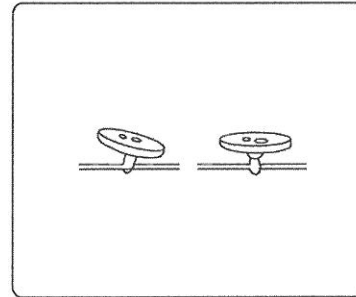
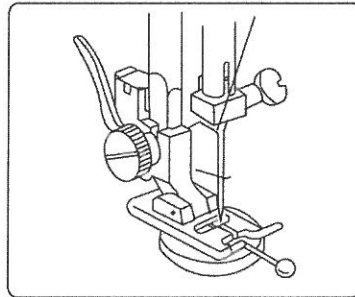

To strengthen the shank, cut the threads leaving a 20 cm (8") tail. Bring the needle thread down through the hole in the button and wind it around the shank.

Draw the thread to the wrong side and knot.

Buttonhole Stitching

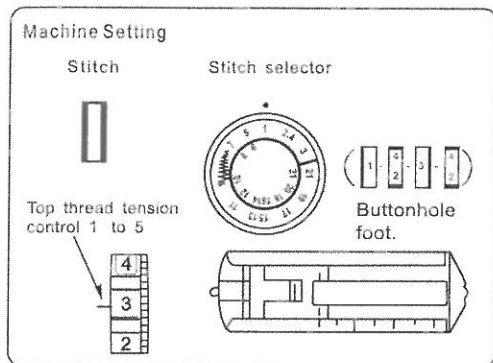

Make a test buttonhole and a sample duplicating the fabric, interfacing and seams of the actual garment. Place the button on the fabric sample and mark the top and bottom to determine the buttonhole length.

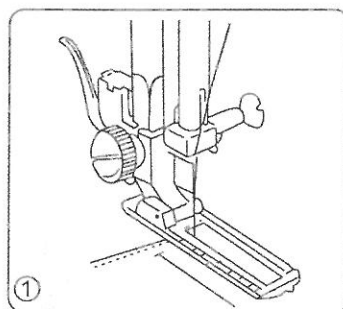

① Set the stitch selector at "1". Slide both threads to the left. Lower the needle into the garment where the buttonhole is to start, and lower the foot.

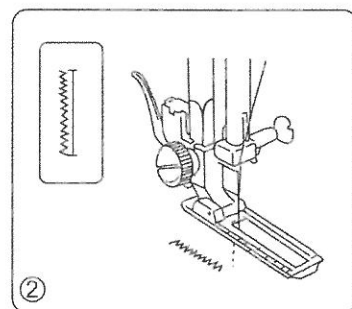

② Sew down the left side stopping at the bottom mark. Raise the needle.

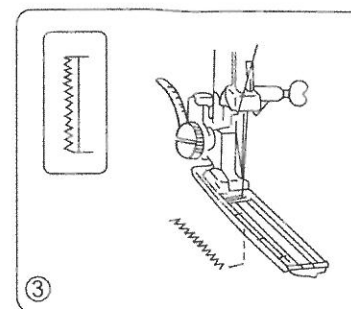

③ Set the stitch selector at "1", sew 5 stitches of bartack and raise the needle up from the fabric.

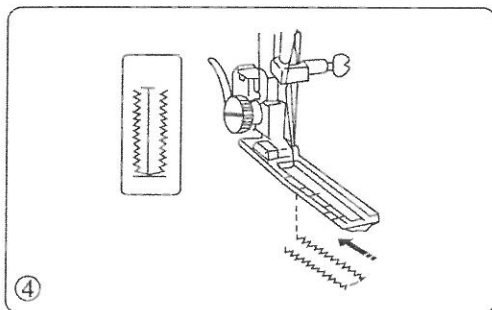

④ Set the stitch selector at "3". Sew up the right side of the buttonhole. Stop the machine when you are directly opposite the first stitch on the left hand side and raise the needle.

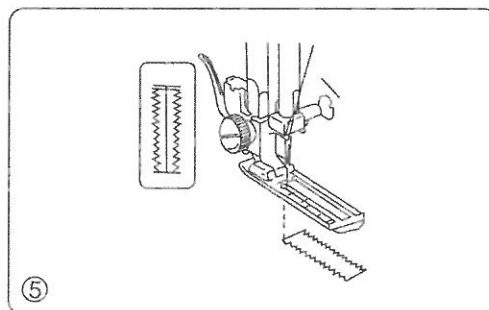

⑤ Set the stitch selector at "2". Sew 5 bartacks stitches and raise the needle up from the fabric. Set the stitch length control to "0" and the stitch selector at straight stitch sewing. Sew a few locking stitches.

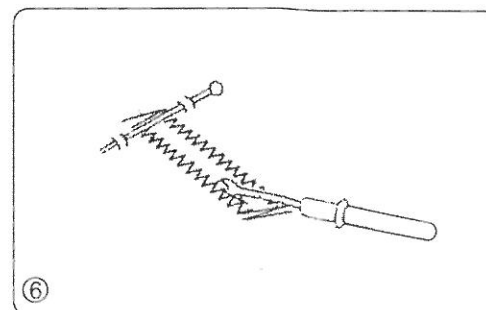

⑥ Remove the fabric from the machine and cut the sewing threads. Insert a pin inside the bartack. Then cut the opening with a seam ripper. Take care not to cut the stitches.

DECORATIVE STITCHING

Shell Tuck

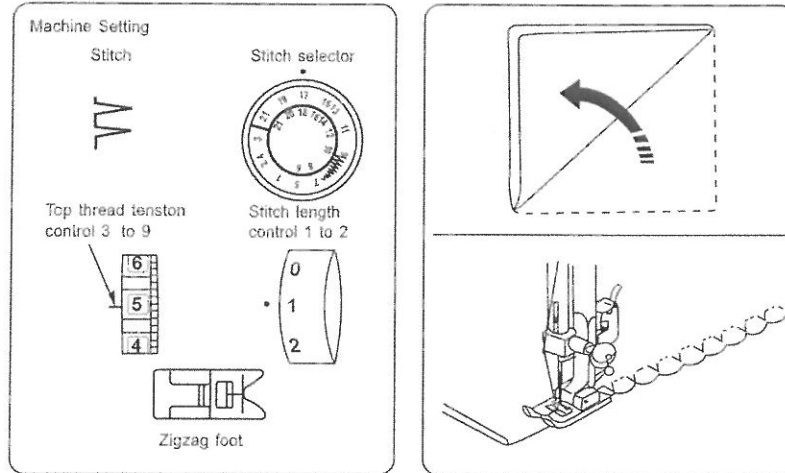

Place the folded edge along the slot of foot. The needle should fall off the edge of the fabric, on the right forming a tuck.

Stretch Stitch Patterns

Machine Setting

Stitch	5	7	9	11	13	15	17	19	21
Stitch selector	6	8	10	12	14	16	18	20	22

Top thread tension control 1 to 4

Stitch length control

Zigzag foot

When forward and reverse feeds become unbalanced depending upon the type of fabric, correct the balance by turning the stitch length control as follows:
 When patterns are compressed, correct it by turning the dial toward "+". (See page 10)
 When patterns are drawn out, correct it by turning the dial toward "-". (See page 10)

When caring for your machine, or cleaning it, unthread it and disconnect the power, even when you change the needle.

Dismantling and Assembling Hook Race

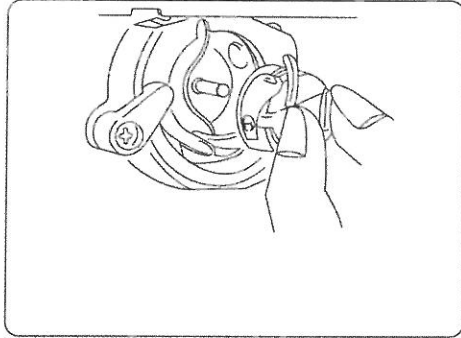

To dismantle hook race:

Raise the needle to its highest position and open the hook cover. Open the hinged latch of bobbin case and take it out of the machine.

CARE OF YOUR MACHINE

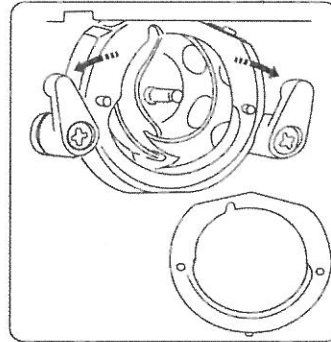

Open the hook race ring holders and remove the hook race ring.

Disconnect your machine from the power source

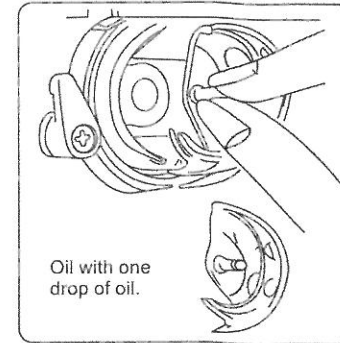

Remove the hook.

* Clean the hook race with a brush and a soft dry cloth.

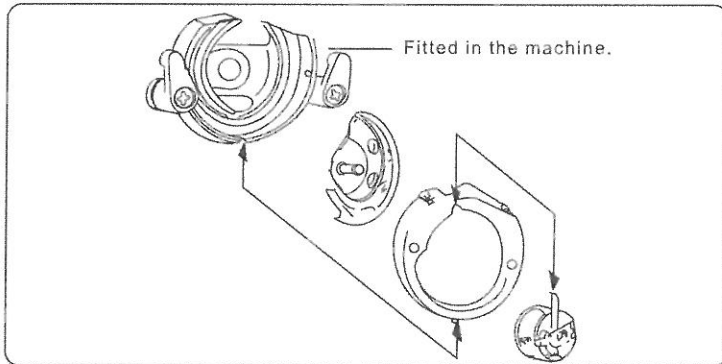

To assemble hook race:

Hold the hook by the center pin and fit it carefully back into the hook race, forming a perfect circle with the shuttle driver. Attach the hook race ring making sure bottom pin fits into the notch. Lock the hook race ring by turning the holders back into position. Insert the bobbin case. Thread the machine and bobbin, connect the machine to the power point and sew switching on the power.

Cleaning the Feed Dogs

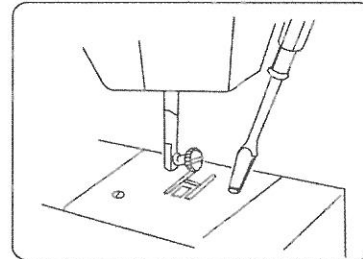

Remove the needle and the presser foot. Unscrew the needle plate set screws and remove the needle plate.

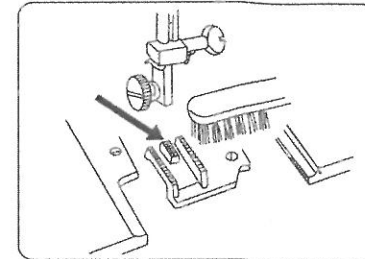

With a brush, clean out dust and lint clogging on the feed dog teeth. Replace the needle plate, tighten screws

NOTE: It is easier if you lay the machine on its back to replace the race.

Trouble Shooting

Condition	Cause	Reference	Condition	Cause	Reference
The machine does not run smoothly and is noisy.	<ol style="list-style-type: none"> 1. Threads have been caught in hook mechanism. 2. The feed dog is packed with lint. 	<p>See Page 18</p> <p>See Page 18</p>	Skipped stitches (Continued)	<ol style="list-style-type: none"> 4. A BALL POINT needle is not being used for sewing stretch, very fine fabrics and synthetics. 5. The needle thread is not threaded properly. 	<p>See Page 5</p> <p>See Page 7</p>
The needle thread breaks.	<ol style="list-style-type: none"> 1. The needle thread is not threaded properly. 2. The needle thread tension is too tight 3. The needle is bent or blunt. 4. The needle is incorrectly inserted. 5. The fabric is not being drawn to the back when sewing is finished. 6. The thread is either too heavy or too fine for the needle. 	<p>See Page 7</p> <p>See Page 8</p> <p>See Page 5</p> <p>See Page 5</p> <p>See Page 11</p> <p>See Page 5</p>		Seam Puckering	<ol style="list-style-type: none"> 1. The needle thread tension is too tight. 2. The machine is not threaded correctly. 3. The needle is too heavy for the Cloth being sewn. 4. The stitches are too long for the fabric being sewn. <ul style="list-style-type: none"> • When sewing extremely light weight materials, Place a sheet of tissue underneath the fabric.
The needle breaks.	<ol style="list-style-type: none"> 1. The needle is incorrectly inserted. 2. The needle is bent or blunt. 3. The needle clamp screw is loose. 4. The tension of the needle thread is too tight. 5. The fabric is not drawn to the back when sewing is finished. 6. The needle is too fine for the fabric being sewn. 7. The stitch selector has been turned while the needle was in the material. 	<p>See Page 5</p> <p>See Page 5</p> <p>See Page 5</p> <p>See Page 8</p> <p>See Page 11</p> <p>See Page 5</p> <p>See Page 9</p>	Stitches form loops below the work.	<ol style="list-style-type: none"> 1. The needle thread tension is too loose. 2. The needle is either too heavy or too fine for the thread. 	<p>See Page 8</p> <p>See Page 5</p>
			The cloth is not feeding smoothly.	<ol style="list-style-type: none"> 1. The feed dog is packed with lint. 2. The stitches are too fine. 	<p>See Page 18</p> <p>Make the stitches longer.</p>
			The bobbin thread breaks.	<ol style="list-style-type: none"> 1. The bobbin thread is not threaded properly in the bobbin case. 2. Lint has collected in the bobbin case. 3. The bobbin is damaged and doesn't turn smoothly. 	<p>See Page 7</p> <p>Clean the bobbin case.</p> <p>Exchange bobbin.</p>
Skipped stitches	<ol style="list-style-type: none"> 1. The needle is incorrectly inserted. 2. The needle is bent or blunt. 3. The needle and/or threads are not suitable for the work being sewn. 	<p>See Page 5</p> <p>See Page 5</p> <p>See Page 5</p>	The buttonhole stitches are not balanced.	<ol style="list-style-type: none"> 1. Stitch length is not suitable for the fabric being sewn. 2. The work is being pulled or held back. 	<p>See Page 9</p> <p>Do not force the fabric for guiding.</p>

Environment



Meaning of crossed out wheeled dustbin:

Do not dispose of electrical appliances as unsorted municipal waste, use separate collection facilities.

Contact you local government for information regarding the collection systems available.

If electrical appliances are disposed of in landfills or dumps, hazardous substances can leak into the groundwater and get into the food chain, damaging your health and well-being.

When replacing old appliances with new ones, the retailer is legally obligated to take back your old appliance for disposals for disposal.



Meaning of crossed out wheeled dustbin:

Do not dispose of electrical appliances as unsorted municipal waste, use separate collection facilities.

Contact you local government for information regarding the collection systems available.

If electrical appliances are disposed of in landfills or dumps, hazardous substances can leak into the groundwater and get into the food chain, damaging your health and well-being.

When replacing old appliances with new ones, the retailer is legally obligated to take back your old appliance for disposals at least free of charge.

This appliance is not intended for use by persons (including children) with reduced physical, sensory or mental capabilities, or lack of experience and knowledge, unless they have been given supervision or instruction concerning use of the appliance by a person responsible for their safety. Children should be supervised to ensure that they do not play with the appliance.